

Surveyor Envoy-MINI 4

Fire Alarm Control Equipment

*Installation, Commissioning
and
Operating Manual*

**MASTER
MANUAL**

CONTENTS

SECTION 1 – INTRODUCTION	<i>Page 4</i>
About this manual	<i>Page 4</i>
System design and planning	<i>Page 4</i>
Panel types	<i>Page 4</i>
General	<i>Page 4</i>
SECTION 2 – INSTALLATION	<i>Page 5</i>
General	<i>Page 5</i>
ESD PRECAUTIONS	<i>Page 5</i>
Cable types and limitations	<i>Page 6</i>
Mains wiring	<i>Page 6</i>
Planning the cable layout in the control panel	<i>Page 7</i>
Fixing the cabinet	<i>Page 7</i>
Mains connections	<i>Page 8</i>
Circuit descriptions and wiring details	<i>Page 8</i>
Figure 4 – general wiring schematic	<i>Page 9</i>
Drawing S1601 – detector base connections	<i>Page 10</i>
SECTION 3 – ENGINEERING OPTIONS	<i>Page 11</i>
General	<i>Page 11</i>
SECTION 4 – COMMISSIONING	<i>Page 12</i>
General	<i>Page 12</i>
Mains connections	<i>Page 12</i>
Powering the panel	<i>Page 12</i>
Connecting the battery	<i>Page 12</i>
Zone circuits	<i>Page 13</i>
Sounder circuits	<i>Page 13</i>
SECTION 5 – FAULT FINDING	<i>Page 14</i>
General	<i>Page 14</i>
Fault latch	<i>Page 14</i>
Zone fault indications	<i>Page 14</i>
Fault finding chart	<i>Page 15</i>

CONTENTS

SECTION 6 – TECHNICAL DATA	<i>Page 16 – 17</i>
-----------------------------------	---------------------

SECTION 7 – OPERATOR INSTRUCTIONS	<i>Page 18</i>
--	----------------

Controls and indications	<i>Page 18 – 20</i>
--------------------------	---------------------

Test mode	<i>Page 21</i>
-----------	----------------

<i>Zone test</i>	<i>Page 21</i>
------------------	----------------

<i>Zone test without sounders</i>	<i>Page 21</i>
-----------------------------------	----------------

<i>Sounder walk test</i>	<i>Page 21</i>
--------------------------	----------------

Disable zones or sounders	<i>Page 22</i>
---------------------------	----------------

<i>Disable zones</i>	<i>Page 22</i>
----------------------	----------------

<i>Disable sounders</i>	<i>Page 22</i>
-------------------------	----------------

Routine maintenance and testing	<i>Page 23</i>
---------------------------------	----------------

USER INSTRUCTIONS

SECTION 1 – INTRODUCTION

About This Manual

This manual is intended as a complete guide to the 4 zone conventional Surveyor ENVOY MINI 4 fire alarm control panel. Installation and commissioning instructions are provided in the first part of the manual with the following sections dealing with technical details and operation. A separate Log Book is also provided.

System Design and Planning

It is assumed that the system, of which this control panel is a part, has been designed by a competent fire alarm system designer in accordance with BS 5839 Part 1: 1988 (from 15th July 2003 this will be BS5839 Part 1: 2002) and with regard to BS EN 54 parts 2 and 4 in the case of control equipment and power supplies. Design drawings should be provided to clearly show the position of any field devices and ancillary equipment.

Panel Types

FCPENV-MINI 4 – A four zone, non extendable control panel with an integral 1.0 Amp PSU and space for 2 x 12V S.L.A batteries. Cabinet size: 277mm Wide x 200mm High x 97mm Deep

General

	<p>This equipment must only be installed and maintained by a suitably skilled and technically competent person.</p> <p>THIS ITEM IS A PIECE OF CLASS 1 EQUIPMENT AND MUST BE EARTHED</p>
---	--

The control panel is a micro-processor controlled, conventional fire alarm control system, comprising of one circuit board. The enclosure consists of back box and hinged, removable lid. Constructed of 1.2mm (18swg) zintec mild steel and powder coated in textured light grey. The enclosure is designed to give protection to IP30 level (for indoor use only)

The control panel is available as a 4 zone only and has no provision for repeater panels.

These panels are designed to comply with the requirements of BS EN 54 part 2 1998, but include integral facilities to enable connection to older systems, which may not comply with current standards.

The control panels are compatible with a wide range of detection and alarm devices. Refer to technical specification for details. The ENVOY MINI4 control panel has integral detector removal monitoring and no special active end of line units are required.

ENVOY MINI4 control panels are simple to install and operate. Control functions are enabled by code entry. The panel fascia is retained by a security cam lock. No internal access is required under normal usage.

<p>Equipment guarantee</p> <p>This equipment is not guaranteed unless the complete system is installed and commissioned in accordance with the laid down national standards by an approved and competent person or organisation.</p>		<p>This product has been manufactured in conformance with the requirements of all applicable EU Council Directives.</p>
---	---	---

SECTION 2 – INSTALLATION

General

- The installation of fire detection and alarm systems should be carried out in accordance with current IEE wiring regulations and in line with B.S.5839 British Standard codes of practice for fire alarm installations. The installation should be carried out by suitably qualified and experienced technicians.
- Care should be taken with regards to avoiding the close proximity of high voltage cables or areas likely to induce electrical interference. Earth links should be maintained on all system cables and grounded in the control panel.
- Any junction boxes used should be clearly labelled FIRE ALARM.
- Any ancillary devices, e.g. door retaining magnets, must be powered from a separate power source.
- Any coils or solenoids used in the system must be suppressed, to avoid damage to the control equipment.

ESD PRECAUTION



Electronic components are vulnerable to damage by Electrostatic Discharges (ESD). An ESD wrist strap, suitably grounded, should be worn at all times when handling pcbs. These wrist straps are designed to prevent the build up of static charges, not only within a persons body, but on many other materials. ESD damage is not always evident immediately, faults can manifest themselves at anytime in the future.

All pcbs should be stored in static shielded bags (silvered) for safe keeping, when not mounted in the control panel. Do not use “black” or “pink” bags and **never** allow pcbs to come in contact with bubble wrap or expanded polystyrene (packing chips).

Static shielded bags and disposable wrist straps are available from the manufacturer.



Warning, Control Panel Access Keys

The keys to the control panel must be kept, safely, by a responsible person. Hazardous voltages may be present. Access to the inside of the panel is not normally required. Disconnect mains supply prior to opening cabinet.

Cable Types and Limitations

All System wiring should be installed to meet BS 5839: Pt 1: 1988 (from 15th July 2003 this will be BS5839: Pt 1: 2002) and BS 7671(Wiring Regulations). Other national standards of installation should be used where applicable

To comply with EMC (Electro Magnetic Compatibility) regulations and to reduce the risk of electrical interference in the system wiring, we recommend the use of screened cables throughout the installation. Acceptable, commonly available, screened cables, which can be used on both the sounder and detector circuits include FP200™, Firetuff™, Firecel™, MICC (Pyro™) or any other cable complying with BS 6387 categories C, W, Z.

Mains Wiring

The mains supply to the fire alarm panel should be hard wired, using suitable three core cable (no less than 0.75mm^2 and no more than 2.5mm^2) or a suitable three conductor system that meets the appropriate national wiring regulations. The panel should be fed from a double pole, isolating, switched, fused, spur, fused at 3A. This should be secure from unauthorised operation and be marked 'FIRE ALARM: DO NOT SWITCH OFF'. The mains supply must be exclusive to the fire panel.

As an alternative to a switched fused spur, a double pole isolating device may be used (see diagram) providing it meets the appropriate national wiring regulations.

NOTE: Any isolating device used, must have a minimum 3mm contact gap.

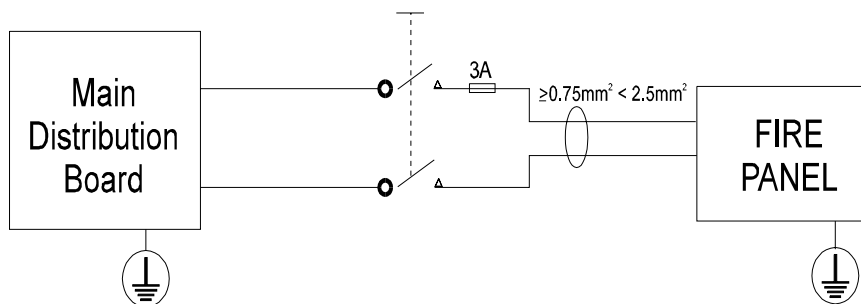

Planning the Cable Layout in the Panel

The detector and sounder circuit cabling is classed as extra low voltage and must be segregated away from mains voltages. Careful planning is needed to ensure this, refer to Figure 1 (below) for guidance and important information on how to remove the panel's knockouts. Always ensure that if a knockout is removed, the hole is filled with a good quality cable gland. Any unused knockouts must be securely blanked off.

Figure 1 : Location of knockouts for cable entry and knockout removal details

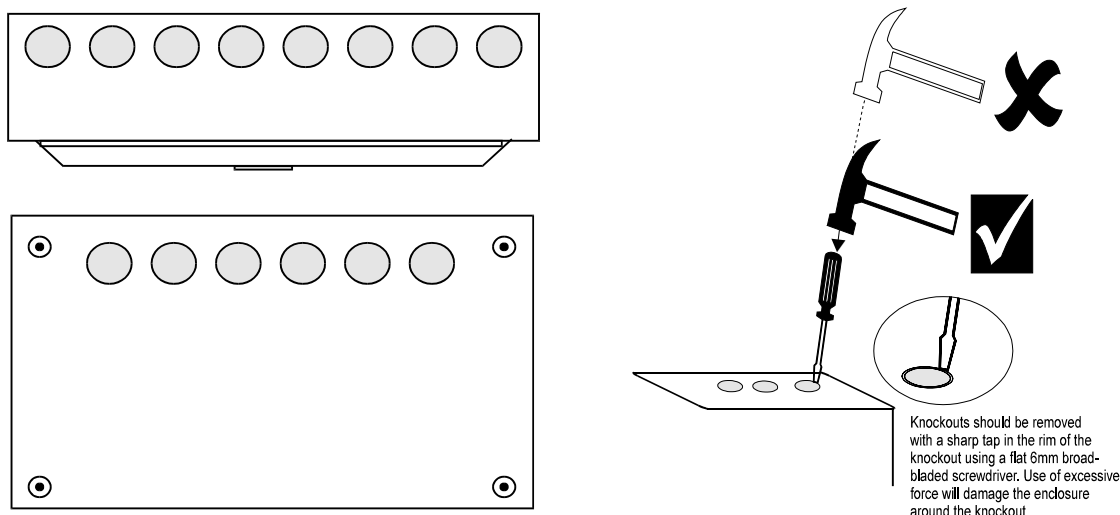

Fixing the Cabinet

Remove outer cover by unlocking the door, drop down fully, remove Earth connection, slide lid to the right, then pull gently towards you. Disconnect transformer and earth connections at top l/h corner of PCB using small terminal driver. The terminals are marked **ac** (white wires) and **Earth** (green and yellow wires). Remove circuit board from back box by unscrewing 3 in number M4 cross headed screws from the circuit board supports. Place circuit board, lid and fixings in a safe position.

Secure cabinet to the wall using the four indented holes in the back box (see figure 2). Ensure that the box is mounted in a convenient location where it may be easily operated and serviced and where it is away from possible sources of vibration or shock, i.e., on partition wall next to a slamming door. External cables should be glanded via pre-formed knockouts at the top and rear of the box as provided. The enclosure should be cleaned of swarf etc., prior to refitting of printed circuit board.

Disconnect the battery leads from the circuit board by a pull out connector at the top l/h corner of the PCB. Insert batteries and connect the battery leads to the battery terminals before replacing circuit board. Ensuring the white link lead is also connected.

Figure 2 : Fixing the cabinet

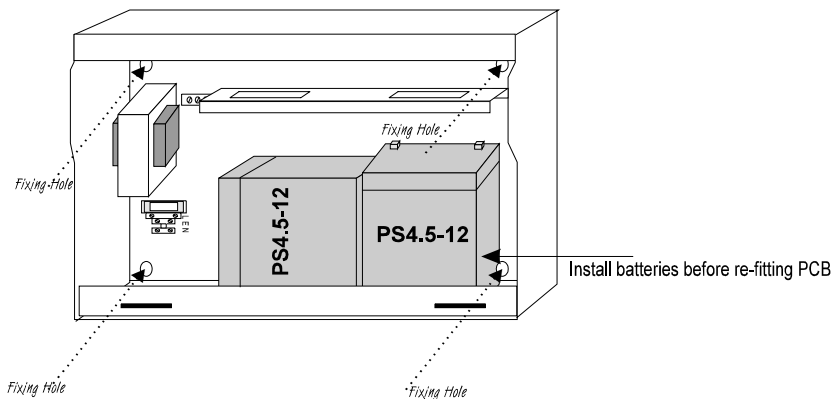

Mains Connections

The general requirements for mains wiring is described on page 5.

Do not connect the mains supply to the panel until you are fully conversant with the layout and features of the equipment. A rating plate is fitted in the bottom left hand corner of the panel describing the nature of the supply permitted.

The incoming mains supply should be brought into the panel in the bottom left hand corner, via the knockout provided. A suitable cable gland must be used to secure the outer sheath of the cable used.

The earth must first be connected to the primary earth stud (peg) marked with a  symbol using ring crimp provided.

Sufficient earth lead should be left to allow Live and Neutral connections to be accidentally pulled from terminal block, while leaving earth connection intact. Secondary earths may be connected to the brass earthing block.

Figure 3: Mains block and earth stud connections

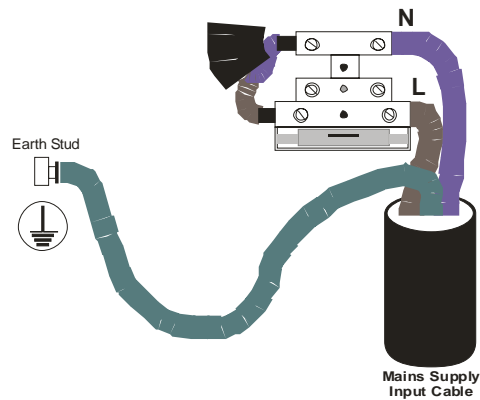

Circuit Descriptions and Wiring Details

MAIN CONTROL PCB (PCMINI4)

SNDR 1 & 2	2 conventional monitored sounder circuits, 28vdc reverse polarity monitored, 4K7 end of line. Both circuits fused at 500mA. Maximum panel sounder load 1 Amp.
ZONE 1 – 4	Conventional 2 wire zone with in built, schottky diode type, detector removal monitoring. Can be used with zener diode type bases via SW3 on DIL switches. Maximum detector load 3mA. 4K7 EOL
P	Precinct or class change switched –ve input. When grounded, activates sounder circuits. Non latching, non silenceable
COMMON FLT	Clean c/o contacts, fail safe, unfused, maximum load 1 amp @ 50vdc
COMMON FIRE	Clean c/o contacts, unfused, maximum load 1 amp @ 50vdc
28v DC OUTPUT	Fused 500mA 28vdc supply output for powering relays etc. Not recommended for door retainer supply.

Figure 4: General wiring schematic

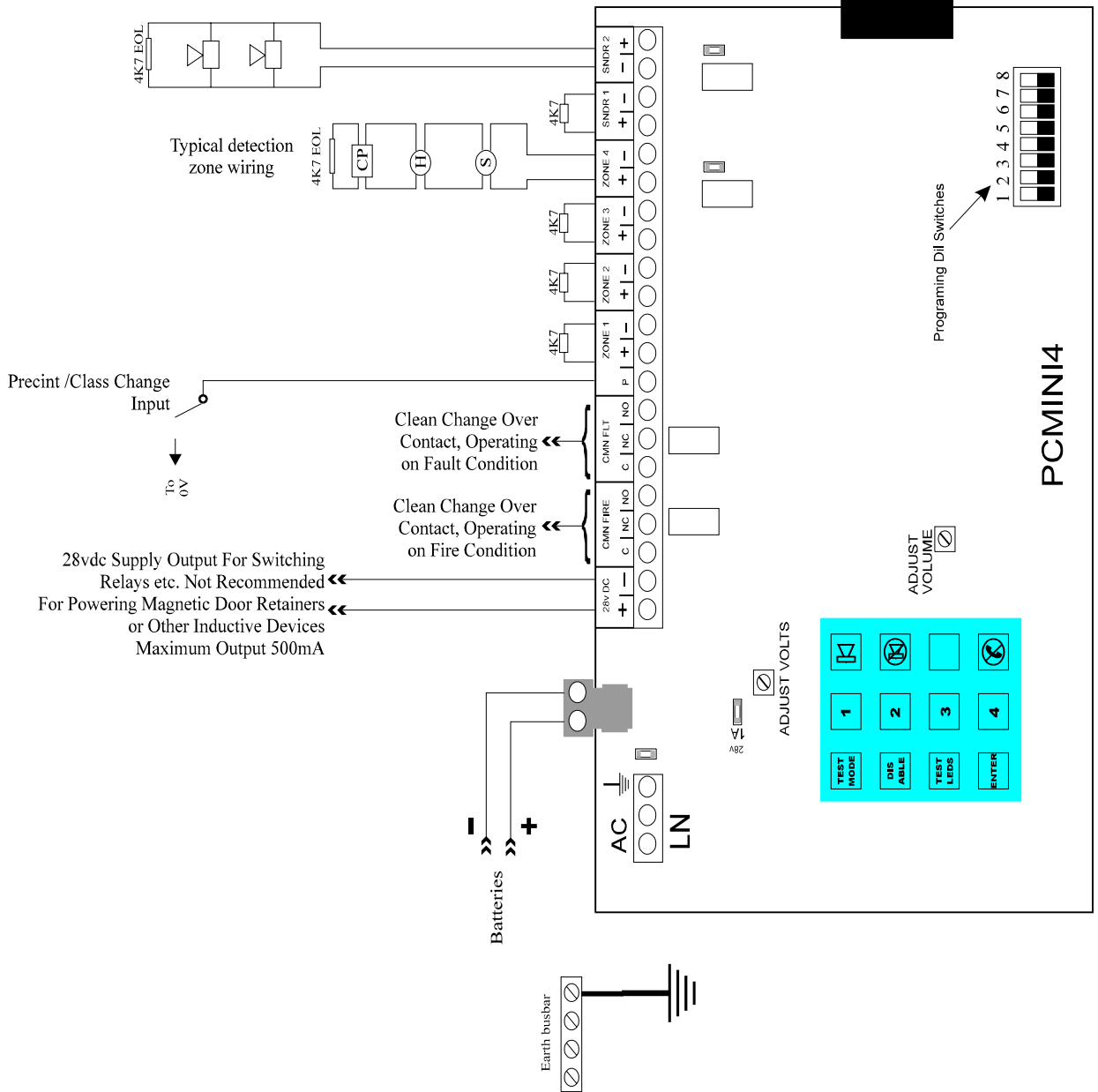

Drawing S1601: showing detector base connection



CDX RANGE DETECTORS

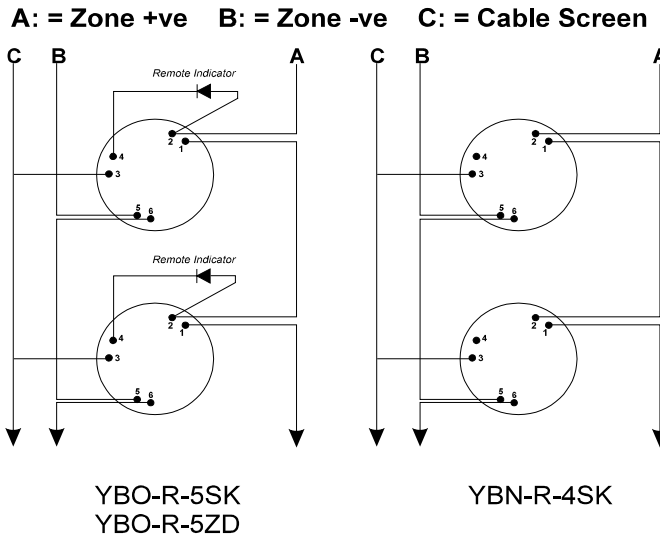

Series 60 DETECTORS

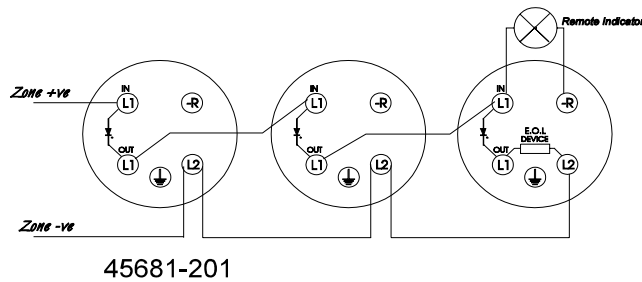

NITTAN (UK) LTD SENORTEC RANGE DETECTORS

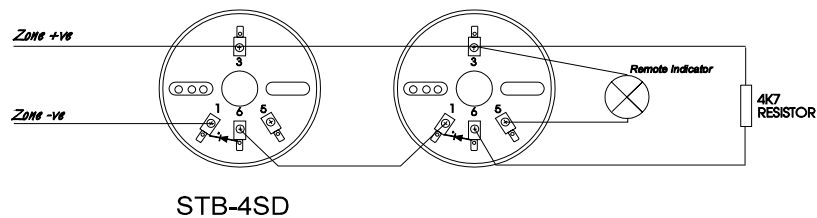

SECTION 3 – ENGINEERING OPTIONS

General

The panel has various options which are programmed by the selection of DIL switches. This section explains which switch relates to which option.

DIL SWITCHES ON MASTER PCB, PCMINI4

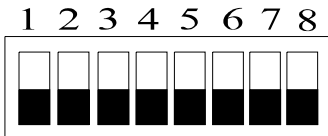

Switch	Function when 'off'	Function when 'on'
1	Faults non latching	Faults latch. Press Reset to clear
2	Short circuit = fault, all zones	Short circuit = fire, all zones
3	Detector removal, by Schottky diode method, all zones	Zener diode head removal, Hochiki YBO-R-5ZD or Apollo 45681-350, all zones
4	Aux contacts operate for all zones	No aux contacts for zone 4
5	Sounders activate for all zones	No sounders operate for zone 4
6	Sounders continuous for zone 4	Sounders pulse for zone 4
7	Zone 4, latching fire	Zone 4, non latching fire
8	Activate controls code = 1234	Activate controls code = 2411

SECTION 4 – COMMISSIONING

General

The commissioning procedures should be completed one step at a time, as described below, to avoid unnecessary problems. By following a logical sequence any faults that may occur can be quickly identified and rectified before moving on to the next step.

Before connecting external circuits to the control panel it is recommended that the panel is powered up and tested, and any faults cleared before proceeding.

Ensure that 4K7 resistors are fitted into zone and sounder circuit terminals before applying power.

To clear the battery fault indication when the mains is connected, a battery must be connected to the battery terminals; it is not possible to inhibit the battery fault by the insertion of a resistor.

The system may be operated on the battery supply, i.e. if the mains supply is not available.

Powering the Panel

Remove the fuse from the mains input. Connect the supply wiring to the terminal block. Check that all connections are sound and that 4K7 EOL resistors are fitted to zone and sounder circuits.

Refit the fuse and switch on the mains supply. The panel LEDs are illuminated momentarily, the ARW LED remains lit and a battery fault is indicated. The internal buzzer sounds.

Connecting the Battery

The standby battery comprises two 12V, S.L.A. cells of a capacity suitable for the required standby period and total alarm load.

Batteries may be located in the panel or in a separate cabinet depending on the battery size.

Battery leads are provided, including a battery link.

The SUPPLY HEALTHY LED should now be illuminated. The ARW LED should be illuminated and the internal buzzer pulsing.

Enter Activate Controls code, (default code is 1234 ENTER) and press RESET.

All the LEDs are lit momentarily, the ARW LED should extinguish and the buzzer should be silent. The panel is now operating correctly in the quiescent mode.

Any faults that are indicated at this stage should be investigated and cleared before proceeding. If necessary refer to the fault location chart on page 13 for further information.

If unfamiliar with the Surveyor ENVOY Series equipment, it is advisable to explore the panel operation and become conversant with the controls before proceeding. Faults can be simulated by open and short circuiting zone and sounder circuits, fire alarms can be generated by shorting the zone terminals with a 470R resistor. Refer to the Operation section if required.

Disposal of Batteries



Respect the environment. Batteries must be disposed of responsibly and in accordance with any local regulations.

Zone Circuits

The default mode of operation assumes that the zone circuit is configured for open and short circuit fault monitoring, and detector removal monitoring, i.e. detector bases are fitted with a suitable diode.

If these conditions do not apply, e.g. when connecting a circuit from an existing system, the operating parameters for each affected zone must be changed. Refer to the Engineering Options section for details.

It is recommended that each zone is connected in turn and its operation proved before moving on to the next zone.

Check that all detectors are fitted into their bases and that a 4K7 Ohm resistor has been fitted to the last device. Remove the 4K7 Ohm resistor from the selected zone terminals and connect the zone pair, observing polarity.

If a zone fault is indicated, investigate and clear before proceeding to the next circuit. If necessary refer to the fault location chart on page 13.

Continue to connect each zone circuit until all are connected and fault free.

It may be preferable to test the operation of zone devices before proceeding with the connection of sounders.

Sounder Circuits

The MINI 4 has two common sounder circuits. .

Polarised and suppressed sounders should be connected in a parallel circuit with no spurs or tees. Ensure that the load of the sounders is within the individual circuit limits, and that the total load does not exceed the panel limits, taking into account any additional load imposed by auxiliary circuits, repeaters, etc.

Remove the 4K7 Ohm resistor from the relevant sounder circuit terminals and connect the circuit pair, observing polarity. Ensure that a 4K7 Ohm resistor is fitted in parallel with the last device on the circuit.

Clear any faults before proceeding – refer to the fault location chart on page 12 if necessary.

Sounders can be tested by operating the SOUND ALARMS push button.

SECTION 5 – FAULT FINDING

General

A fault is indicated by the illumination of the SYSTEM FAULT LEDs and a buzzer tone. Specific faults are identified by additional fascia indicators, e.g. zone fault. The buzzer tone varies depending on the fault and may, or may not, be silenceable.

Fault Latch

If an intermittent fault exists, it is possible to make all fault indications latch, to help identify problems. To activate fault latch, select option DIL switch 1 to ON.

Zone Fault Indications

Steady zone fault LED =	Zone in test or disabled
Pulsing zone fault LED =	Zone in fault condition

Identify the nature of the zone fault with the following method. When a zone fault is present:

Press and hold:

Button 1 to identify open circuit fault

Button 2 to identify short circuit fault

Button 3 to identify detector removed fault

If the zone fault indication remains when any of the buttons are pressed then that is the fault identified. If the indication clears when the button is pressed then that fault is not present.

Fault Finding Chart

The following chart identifies the indications that may be displayed, with the possible cause and the recommended action. Fault location should be tackled logically by isolating fault paths until the source is apparent, e.g. disconnecting zone and sounder circuits to prove if the fault is on the circuit or in the panel, etc. Faults on external circuits can be traced by breaking down the circuit, e.g. placing the EOL at the mid point of the circuit and determining which half is affected.

<i>Panel Indication</i>	<i>Possible Cause</i>	<i>Action</i>
System Fault (System Healthy extinguished)	Mains failure/fuse failure Battery disconnected or open circuit. Battery Fuse failed Voltage too high (>30V) or too low (<19V)	Check supply/fuse Check battery/fuse Adjust to 27.6V. Measure voltage using the battery terminals on pcb, with the batteries disconnected.
System Fault	Sounder circuit open circuit (LED slow pulse) or short circuit (LED fast pulse)	Check circuit integrity/EOL Sounder not polarised or reverse polarity – correct fault
System Fault + Zone Fault	Zone open circuit (LED slow pulse) Zone short circuit (LED fast pulse)	Confirm fault is on external circuit by disconnecting zone wires and fitting 4K7R in zone terminals. Check EOL and circuit connections
System Fault + Zone Fault + Detector Removed	One or more detectors removed Base(s) wired incorrectly Incompatible detector(s) Panel faulty	Replace detector(s) Check wiring/diodes Consult supplier
Test Mode + Zone Fault or Detector Removed	System in Test Mode	Reset system to exit test mode
ARW	Illuminates when panel is first powered up. Internal microprocessor has auto reset due to spurious power surge/interference	Reset panel. If condition persists, consult supplier
Zone Disabled	Zone isolated	Re-instate zone (refer to programing if necessary)

SECTION 6 – TECHNICAL DATA

- Mains input voltage ; 230Vac, 50-60 Hz (Harmonised) +10% to -15% compliant with BSEN54 Pt4 : 1997 for fire alarm power supplies.
- Nominal system voltage 24V dc.
- Power supply : Current limited 1amp suits SLA batteries only. Charging voltage 27.6 volts +/- 0.2V
- Temperature range: -5 to +40° C. Maximum relative humidity = 95%.

GENERAL DATA & CURRENT CONSUMPTION FIGURES

<i>Part No</i>	<i>Zones</i>	<i>Description</i>	<i>Qty Conventional Sndr ccts</i>	<i>Total Sndr Load (Amps)</i>	<i>Quiescent Current</i>	<i>Panel Only in Alarm</i>
FCPENV-MINI4	4	Compact non extendable	2	1	57mA	100mA

BATTERY SIZES

The panel has space for the following batteries, based on standard sizes as supplied by the manufacturer.

<i>Part No.</i>	<i>Batteries</i>
FCPENV-MINI4 Cabinet Size: 277W x 200H x 97D mm	2 x 1.2Ah 12 Volt SLA 2 x 2.0Ah 12 Volt SLA 2 x 4.5Ah 12 Volt SLA

Detector Zones: Voltage 17 – 28V dc. Quiescent current 3.5mA each. End of line value 4K7 Ohm. Schottky diode or zenner clamp detector removal monitoring.

Sounder Cicuits: 17 – 28V dc reverse polarity monitored. Sounders must be polarised and suppressed. End of line value 4K7 Ohm. Output current 500mA. Maximum shared sounder load 1.0 amp.

Fuses:
Mains: F 2A H, 250vac, 20mm HBC ceramic. Compliant with IEC (EN60127 Pt.2)
Battery: 1 amp, nanofuse, fast acting
Supply: 1 amp, nanofuse, fast acting
Sounders: 500mA, nanofuse, fast acting

Technical Data Continued

SUITABILITY (RECOMMENDED EQUIPMENT)

	Conventional:
Smoke / Heat Detectors	Nittan: Sensortec Range STB-4SD schottky base
	Apollo: Series 60 45681-201 schottky base
	Hochiki: CDX Range YBN-R-4SK schottky base YBO-R-5ZD zenner base
Call Point	KAC: WR2072-SR, 470 OHM Resistor
Sounders	Use polarised and suppressed, light current 24vdc electronic sounders or bells (Fulleon, Besson etc.)

SECTION 7 – OPERATOR INSTRUCTIONS

Controls and Indications

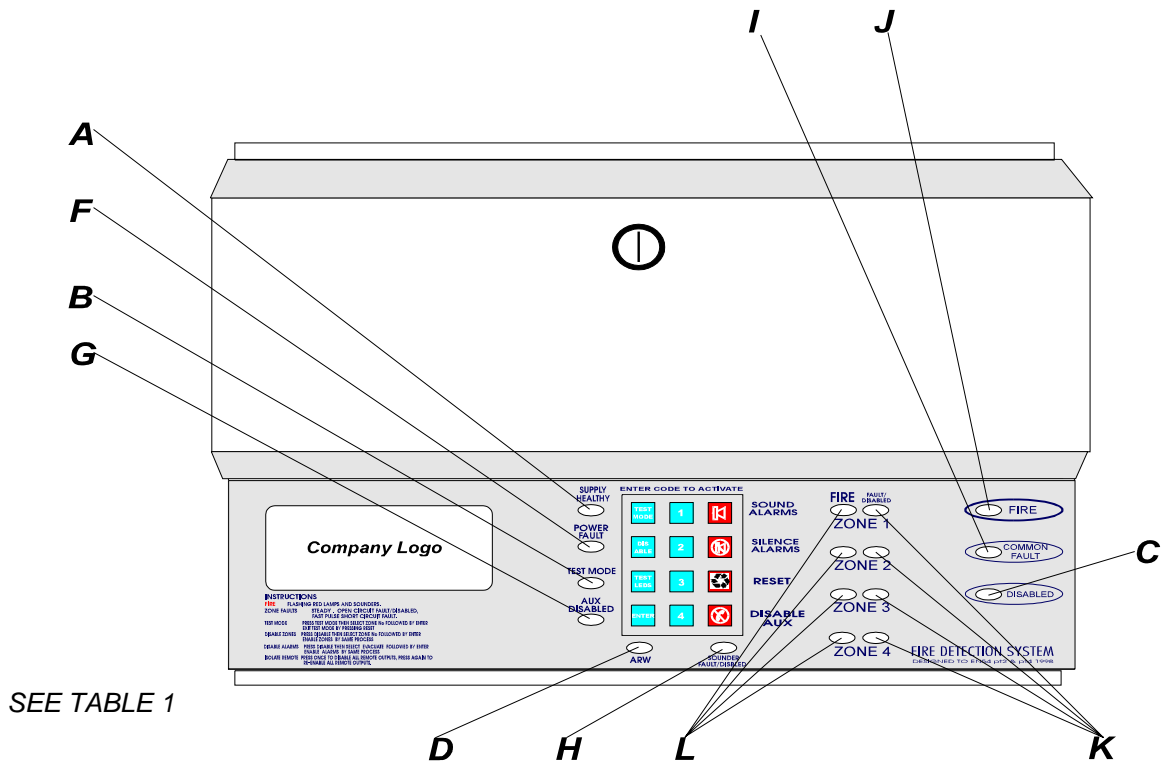

SEE TABLE 1

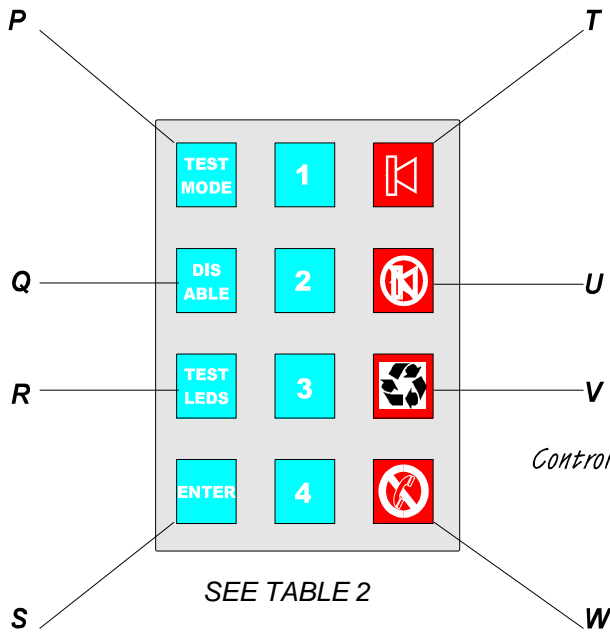

Enter code to activate keypad controls.

Control Panel Keypad

SEE TABLE 2

Controls and Indications Continued

TABLE 1

A	SUPPLY HEALTHY	Indicates permanently when panel is correctly powered.
B	TEST MODE	Pulses when the control panel is in engineer's test mode. The individual circuit fault lamp will be on (steady) whilst the circuit is in test mode. It is not possible to test a disabled zone. See page 20 "Test Mode" for more details.
C	DISABLED	Indicates when a zone or sounder circuit has been disabled using the disable button on the keypad. The LED remains on steady if any disablement is present on any of the circuits. The individual circuit fault lamp will be on (steady) whilst the circuit is disabled. See page 21 "Disable Zones or Sounders" for more details.
D	ARW	Automatic Reset Warning, Indicates if the processor has been rebooted. Will indicate when panel is first powered up. See fault finding section for more details. Reset panel to clear indication.
E	"ENABLE CONTROLS" KEY-SWITCH (OPTIONAL)	Optional Key-switch to activate the buttons on the keypad. They do not function unless this switch is in the on position. This can be fitted retrospectively.
F	POWER FAULT	Indicates a fault with the power supply. A fast pulse = battery fault. A slow pulse = voltage faults. An intermittent blip = mains fault. See fault finding section for more details.
G	AUX / DISABLED	Indicates if the remote relay outputs have been isolated using the isolate remote button on the keypad.
H	SOUNDER CIRCUIT FAULT	Indicates that there is a fault on the individual sounder circuit or that the sounders have been disabled or are in test mode. A fast pulse = short circuit. A slow pulse = open circuit. Sounder circuit fault LEDs are on (steady) for disabled or test mode. Note:- disablement or test mode will have priority. See fault finding section for more details.
I	COMMON FAULT	LED Indicates when any fault occurs. Note:- when a mains failure fault is present the LED blips intermittently to conserve the batteries. See fault finding section for more details.
J	COMMON FIRE	LED Indicates when any zone is in fire. Pulsing when fire or evacuate is active, will steady when alarms silenced.
K	ZONE FAULT / DISABLED / IN TEST	Indicates that there is a fault on this zone, or that the zone is in test mode, or has been disabled. LED on (steady) in "test mode" or "disabled". A slow pulse = open circuit. A fast pulse = short circuit. Note:- disablement or test mode will have priority. See fault finding section for more details.
L	FIRE ON ZONE	Indicates that there is a fire condition on this zone. Pulses when in fire, will steady when alarms silenced. New zones in fire will pulse until silence alarms is pressed again while the existing silenced zones will remain steady.

Controls and Indications Continued

TABLE 2

P	TEST MODE	"Test mode" button. Puts zones into test mode. See relevant section, page 20.
Q	DISABLE	"Disable" button. To disable or isolate zones or sounder circuits. See relevant section, page 21.
R	TEST LEDs	Pressing this button will cause all LEDs to illuminate briefly.
S	ENTER	"Enter" button. Used to acknowledge selection of zone or sounder circuits for disablement. Also mutes internal fault buzzer when active and to enter code number for controls activate.
T	SOUND ALARMS	"Sound alarms" button. To sound all bells and activate remote fire outputs for full evacuation.
U	SILENCE ALARMS	"Silence alarms" button. To silence bells or sounders. The internal buzzer will blip intermittently until the system has been reset.
V	RESET	"Reset" button. To reset system. When the panel is in fire condition reset will only function if the "silence alarms" button has been pressed first.
W	DISABLE AUX	Isolates the remote fire and fault relays for system testing purposes. Press again to reinstate them.

Test Mode

ZONE TEST

To put zone(s) into test mode, enter code to activate controls and press the **TEST MODE** button on the keypad. Now use buttons 1 – 4 to select which zone(s) to put into test mode and press **ENTER** when all selections have been made. The test mode entry will “time out” within 5 seconds if the **ENTER** button is not pressed. It is possible to have any or all zones in test mode at the same time. The Test Mode LED will be on. The fault LED of the zone(s) in test mode will be illuminated and the internal buzzer will be sounding. The operation of any smoke detector or call point will now ring all bells or sounders for one second. The panel will automatically reset, providing that the detector is clear of smoke or the call point glass is back in position. The alarms will then sound momentarily to acknowledge that the panel has reset, so you can move on to the next device. Press the **RESET** button on the keypad at any time to exit Test Mode.

The removal of a detector while in test mode will also cause the alarms to sound for one second and then again momentarily when the detector is replaced, thus enabling a Detector Removal Monitoring Walk Test. **N.B the panel may take a few seconds to recognise a detector has been removed due to it’s normal monitoring cycle.**

ZONE TEST WITHOUT SOUNDERS

To test zones without the operation of any sounders, i.e. visual indications and panel buzzer only. Press the **TEST MODE** button on the keypad followed by buttons 1 – 4 to select the zone(s) to put into test. Then press the **SILENCE ALARMS** button and then **ENTER**. The sounders will now be disabled during all testing. Should a zone which is not in test go into alarm the sounders will operate normally.

SOUNDER WALK TEST

A sounder test can be activated by pressing **TEST MODE** button and then using the **SOUND ALARMS** button instead of buttons 1 – 4. This will cause the panel to sound all the bells for one second every eight seconds, allowing the user to walk to each sounder to check that it is working correctly.

Remember to push each button slowly and deliberately. There is a half second delay on the buttons to prevent misuse. The panel will bleep to acknowledge each push of the button.

Zone Test

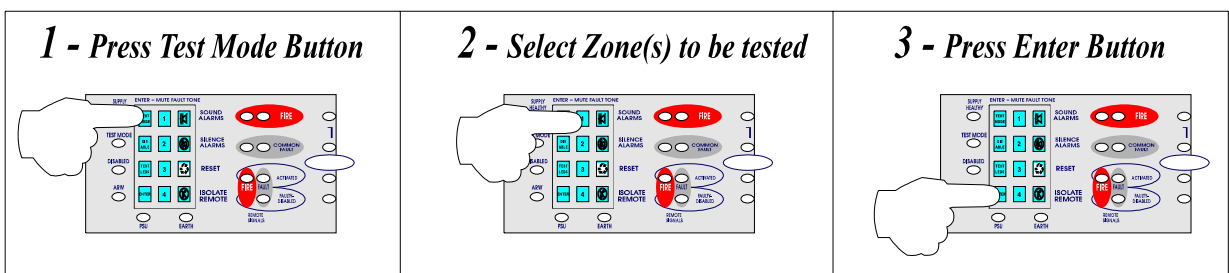

Sounder Test

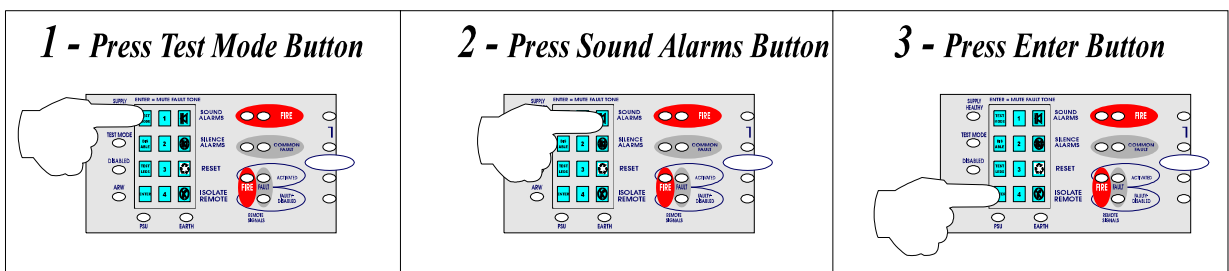

Disable Zones or Sounders

DISABLE ZONES

To disable / isolate zones , enter code to activate controls and press the **DISABLE** button on the keypad Now use buttons 1 – 4 to select which zone(s) to disable and then press **ENTER** when all selections have been made. The disable mode will “time out” within 5 seconds if the **ENTER** button is not pressed. It is possible to select any, or all zones, to be isolated at the same time. The disabled LED will be illuminated. The fault LED of the zone that is disabled will be illuminated and the internal buzzer will be sounding.

DISABLE SOUNDERS

To disable sounder circuits press the **SOUND ALARMS** button instead of buttons 1 – 4 (see above) and then press **ENTER**. The sounder fault LED and the disabled LED will be illuminated.

To ‘enable’ the zones or sounder circuits again, simply repeat exactly the same procedure. **WARNING zones and sounder circuits that have been disabled cannot be enabled by the use of the RESET button.**

Remember to push each button slowly and deliberately. There is a half second delay on the buttons to prevent misuse. The panel will bleep to acknowledge each push of the button.

Disable Zones

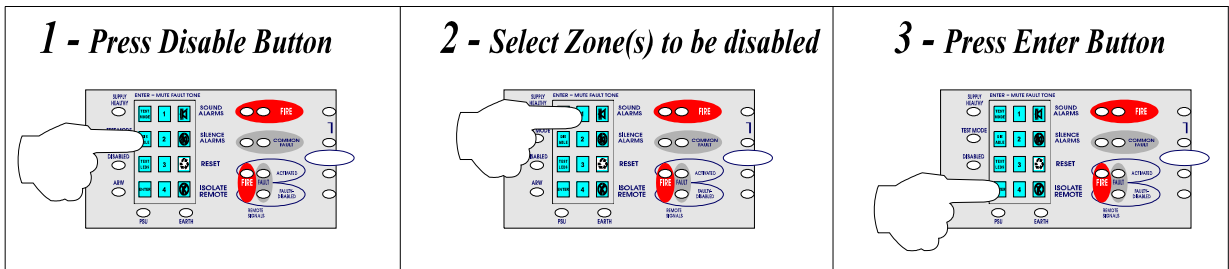

Disable Sounders

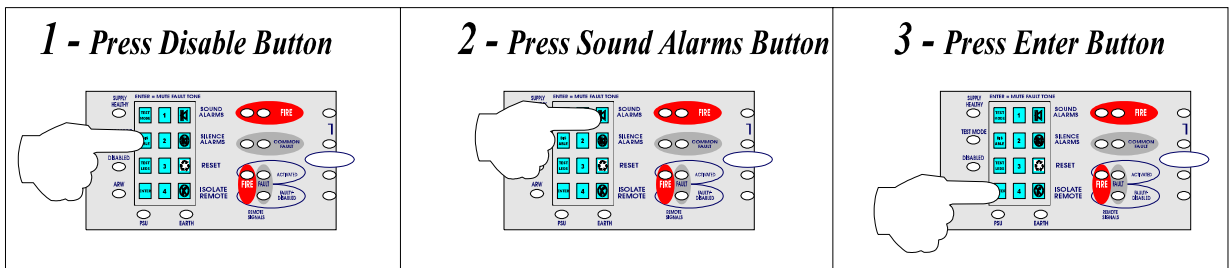

Routine Maintenance and Testing

It is essential that the fire alarm installation is checked regularly by a responsible person for correct operation in accordance with EN54 Part 2 or BS5839 Part 1. or applicable standard.

CLEANING

The exterior of the cabinet may be cleaned when required using a clean, moistened cloth. Do not use solvents or abrasives as these will damage the panel.

ROUTINE TESTING

Routine checks should be carried out as detailed in this section of the manual. It is essential to keep the log, in order to maintain a record of tests, checks, alarms and faults. A log book is provided with this instruction manual. The log book should be kept with the panel and be available for inspection by an authorised person.

DAILY

Check that the green, "SUPPLY HEALTHY", indicator is lit. If the indicator is not lit, record the fact in the log book and call for a qualified electrician to check the power supply.

WEEKLY

Carry out the daily check.

Operate one detector or call point on one zone and check that the panel responds to the alarm and operates the warning devices. Record the results of the test and the zone detector/call point operated, in the log book. A different zone detector/call point should be operated each week, to ensure that all detectors/call points are tested in turn.

Visually inspect the batteries and all connections and ensure that they are in good condition. Visually inspect all call points and detectors and ensure that none is, in any way, obstructed or damaged.

QUARTERLY

Check all previous entries in the log book and ensure that all necessary remedial action has been carried out.

Carry out the daily check.

Carry out the weekly test.

Isolate the mains supply, then test that the battery is capable of operating the warning devices by operating a detector or call point.

Reconnect the mains supply. Record the results of the tests in the log book.

ANNUALLY

Carry out the daily, weekly and quarterly tests. Test all the detectors and call points for correct operation. Visually inspect all cable fittings and equipment to ensure that they are secure, undamaged and adequately protected. Record the results in the log book.

EVERY 5 YEARS

Renew the sealed lead acid batteries and record the fact in the log book.

The installation requires to be tested in accordance with the testing and inspection requirements of the Local or National Standards. Any defect should be recorded in the log book and action should be taken to correct it.

DETECTORS

Renew or return the smoke detectors for cleaning, as directed in the manufacturer's data, to ensure correct operation and freedom from false alarms. Cleaning smoke detectors is a specialised activity. If in doubt consult the supplier. Record the actions in the log book.

NOTE: *Ionisation smoke detectors contain a radioactive source and should only be disposed of in the recommended manner. Contact your Service Company for further advice.*

USER INSTRUCTIONS

Alarm Condition

If all sounders or bells are ringing, the system is in an alarm condition. **YOU MUST EVACUATE THE BUILDING OR FOLLOW YOUR NORMAL FIRE DRILL PROCEDURES.**

A responsible person should then:-

- 1 Check the control panel to see which area or zone has caused the system to go into alarm. The zone in alarm will be indicated by a red, flashing, light on the front of the control panel, see fig 1.
- 2 Go to the area which has caused the alarm to check if a fire exists.
- 3 Only when it is safe to do so should the alarms be silenced. Enter the activation code, press ENTER and then press the SILENCE ALARMS button, see fig 2. If it was a false alarm look for the device that has caused the alarm. A detector will have a red light lit, or check to see if a call point glass is broken. (If so replace the glass or call an engineer.)
- 4 When fully satisfied that there is no fire, return to the control panel and press the RESET button, see fig 3. Once the system has been reset the light on the detector should extinguish and only the green SUPPLY HEALTHY lamp should be lit on the control panel.

If the system continues to false alarm, call an engineer.

Tear Here

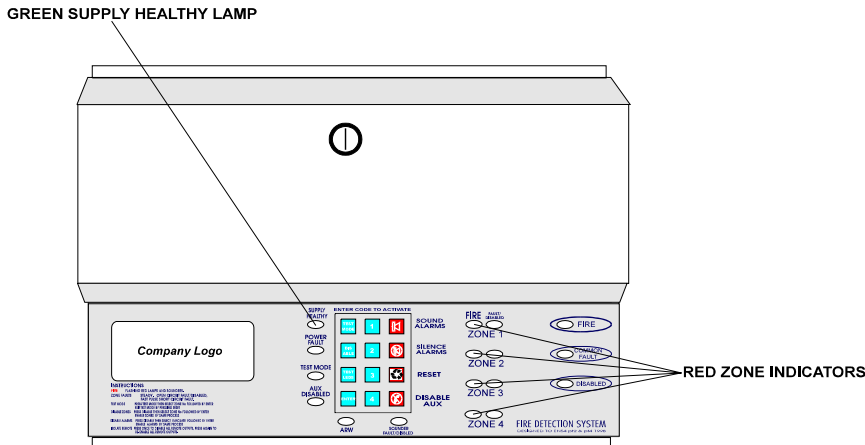

Figure. 1

1 - Enter code

1 - 2 - 3 - 4 ENTER

2 - Press Silence Alarms

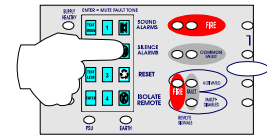

Figure. 2

3 - Press Reset Button

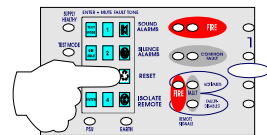

Figure. 3

Fault Condition

If a buzzer is sounding in the control panel but the sounders or bells are not ringing, then there is either a fault on the system or zones / sounders have been disabled. **Call an engineer.**

The internal fault buzzer can be silenced by pressing the ENTER button. **DO NOT RESET THE SYSTEM UNTIL AN ENGINEER HAS INVESTIGATED THE FAULT.**

See relevant section in the installation and operating manual for details of disabling and enabling zones and sounders.